



SFC-200 SERIES LCD FIRE ALARM PANEL



USER GUIDE

Contents

Introduction	1
About this Manual	1
Technical Support	1
Main Display	1
The Buzzer and LED Indicators	2
Buzzer	2
AC On LED	2
Alarm LED	2
Supervisory LED	2
Trouble LED	2
CPU Fail LED	2
Main Display Buttons	3
System Reset Button	3
Signal Silence Button	3
Fire Drill Button	3
Lamp Test Button	3
Buzzer Silence Button	3
The Up and Down Arrow Buttons	3
The Info Button	3
The Enter, Menu, and Cancel Buttons	3
Disconnecting/Reconnecting a Circuit (Zone)	4
Understanding On-screen Messages	5
Common Messages	6
Glossary	10

Introduction

About this Manual

This user's guide provides information on the main indicators and controls of the SFC-200 Fire Alarm Control Panel. Specifically, with this manual you will learn about:

- What the LEDs on the main display indicate
- What the buttons on the main display do
- What certain common LCD screen messages mean

Refer to the **Glossary** on page 11 for an explanation of commonly used terms in this manual.

Technical Support

For all technical support inquiries, please contact Mircom's Technical Support Department between 8 A.M. and 5 P.M. (EDT) Monday through Friday, excluding holidays.

Local Phone: 905-695-3549

Toll-Free Phone: 1-866-786-6420 (1-866-SUMMIT-0)

Local Fax: 905-660-4113

Toll-Free Fax: 1-888-660-4113

Main Display

Refer to the diagram below for the LCD display, LED indicators, and control buttons locations.

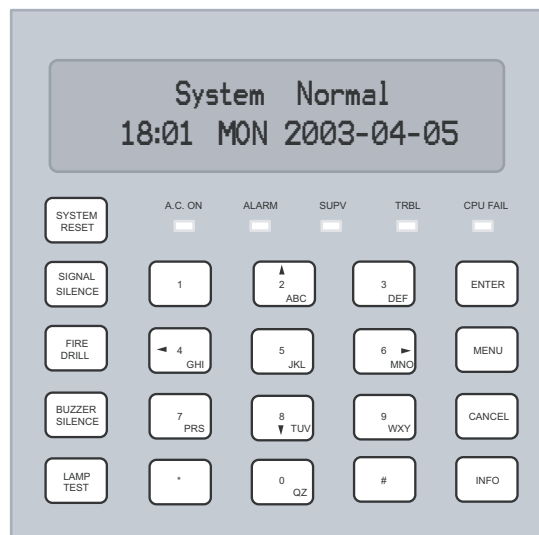

The main display panel on the fire alarm control board consists of:

- Five LED indicators (located just below the LCD screen)
- Five buttons (left edge of display)
- 16 program buttons (right part of display)

LED indicators may be amber, red, or green, and may illuminate continuously (steady), or at one of two flash rates:

- **Fast flash (supervisory):** 120 flashes per minute
- **Trouble flash (trouble):** 20 flashes per minutes

The Buzzer and LED Indicators



Buzzer

The buzzer sounds if there is a fire alarm, a supervisory alarm, or a trouble in the fire alarm system. It turns off if the condition causing the buzzer to sound goes away or the Buzzer Silence button is pressed.

AC On LED

The green AC On LED illuminates steadily as long as the main power is above minimum level. The indicator turns off when the level falls below the minimum level and the panel switches to standby (battery) power.

Alarm LED

The red Alarm LED will illuminate steadily whenever there is a fire alarm. This indicator will remain on until the system is reset.

Supervisory LED

The amber Supervisory LED illuminates at the fast flash rate when there is a supervisory alarm in the fire alarm system. For non-latching supervisory alarms, the Supervisory LED will turn off when the condition causing the alarm goes away. For latching supervisory alarms, this LED remains on until the panel is reset.

Trouble LED

The Trouble LED flashes amber at the trouble flash rate when the panel detects any trouble condition. For non-latching trouble conditions, the Supervisory LED will turn off when the condition causing the alarm goes away. For latching trouble conditions, this LED remains on until the panel is reset.

CPU Fail LED

The CPU Fail LED flashes amber at the trouble flash rate to indicate a microprocessor failure on the main board.

Main Display Buttons

System Reset Button



The System Reset button resets the fire alarm control panel and all circuits.

Signal Silence Button



Pressing the Signal Silence button when the panel is in alarm deactivates any silenceable signal devices in the fire alarm system. Non-silenceable signal devices are unaffected. If you press the Signal Silence button a second time, or if there is a subsequent alarm, the signals will re-sound. If the panel has been configured with a Signal Silence Inhibit timer, this button will not work until the timer times out. This button also does not work if you have pressed the Fire Drill button.

Fire Drill Button



Pressing the Fire Drill button will simulate a fire alarm by activating the fire alarm signals without transmitting an alarm to the central station. To cancel the fire drill, press the button again. If the fire alarm system goes into a real alarm while you are performing a fire drill, this button will not turn off the signals or operate any programmed relays.

Lamp Test Button



Pressing and holding the Lamp Test button causes the LCD to display the software version, all the front panel LEDs to illuminate, and sounds the buzzer. Use this button to test that the LCD display and all LEDs on the main display are working. If you hold the Lamp Test button for more than ten seconds, the Trouble LED will illuminate.

Buzzer Silence Button



Pressing the Buzzer Silence button while the buzzer is sounding silences the buzzer. The buzzer will resound if there is a subsequent event. Pressing the button when the buzzer is not sounding has no effect.

The Up and Down Arrow Buttons

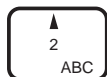

Use these buttons to scroll through any events listed on the screen. The up arrow moves to the next listed condition and the down arrow moves to the previously listed condition.

The Info Button



Press the Info button while there is a message on the LCD screen to view additional information.

The Enter, Menu, and Cancel Buttons

The Enter, Menu, and Cancel buttons are only used by technicians to program the fire alarm control panel.

Disconnecting/Reconnecting a Circuit (Zone)

You can disconnect and reconnect detection and signal circuits (zones) from the panel using the bypass options in the menu.

To select the bypass options, you must be in the Command Menu. To enter the Command Menu, press .

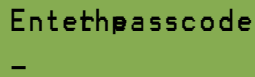

Step 1: Enter your passcode



1. Enter your passcode.
2. Press  to continue.

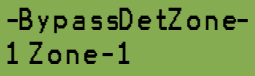





Step 2: Select the Bypass Menu

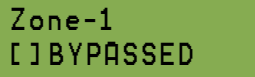

1. Use  and  to scroll the cursor to select the zone you would like to disconnect / reconnect.
2. Press  to continue.

Step 3: Select "BYPASSED" or "UNBYPASSED"



1. Use  and  to scroll the cursor to
 - "Bypassed" to disconnect a circuit
 - or
 - "Unbypassed" to reconnect a circuit
2. Use  and  to toggle the selection ON ("X" appears), or OFF (space is blank).
3. Press  to continue.
4. Press  twice to return to the main menu.

If you have disconnected (bypassed) a circuit, a trouble message will display on the main screen until the circuit is reconnected.

Understanding On-screen Messages

The LCD screen of the fire alarm control panel displays messages regarding system events. System events display on the screen in a queue. Events in this queue are listed on the screen in order of priority: alarms are of highest priority, followed by supervisory, trouble, and monitor conditions. If the same type of event happens more than once (for example, two trouble conditions occur successively) they will be listed in the order of the most recent event to the least recent event. If an alarm, supervisory, or trouble condition occurs, their respective LED will flash.

Scroll through the events by using the  and  arrow buttons. If you need more information about a displayed event, press .

Example 1 (detection circuit)

The message below indicates that event 1 of 9 is an open trouble at the East Lobby Entrance. When  is pressed, the screen shows that the process type is a verified alarm on Z-01 and the event occurred on Tuesday April 4, 2003 at 18:01.

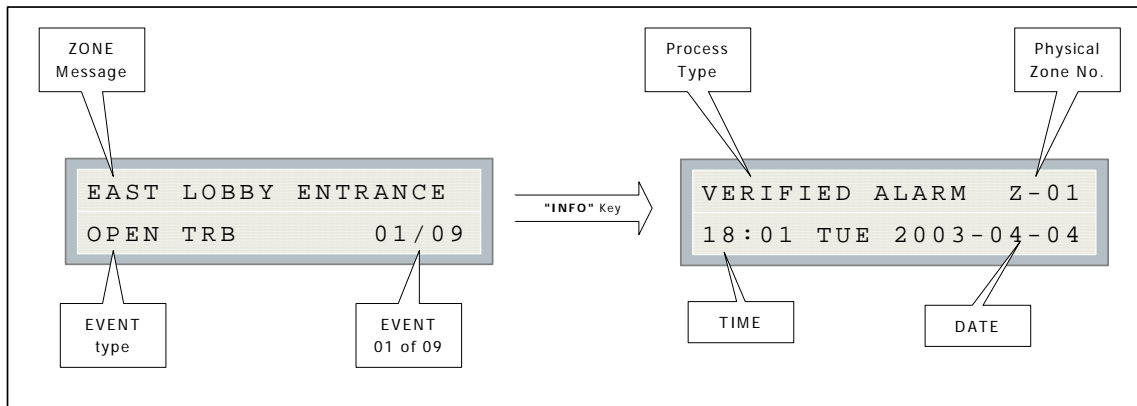

Example 2 (indicating circuit):

The message below indicates that event 2 of 9 is a short trouble at the East Wing Lobby. When  is pressed, the screen shows that the process type is silenceable on NAC-1 and the event occurred on Tuesday February 2, 2003 at 18:01.

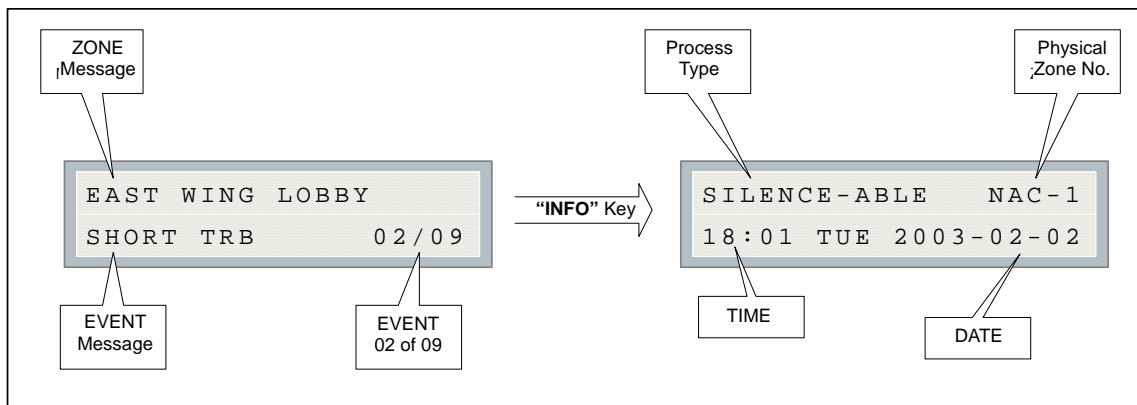

Common Messages

Common system messages are outlined below.

AC Power Fail

The “AC Power Fail” message indicates that the power has dropped below the minimum level and the system is running on backup battery power. The trouble is removed when the power returns to the normal value.

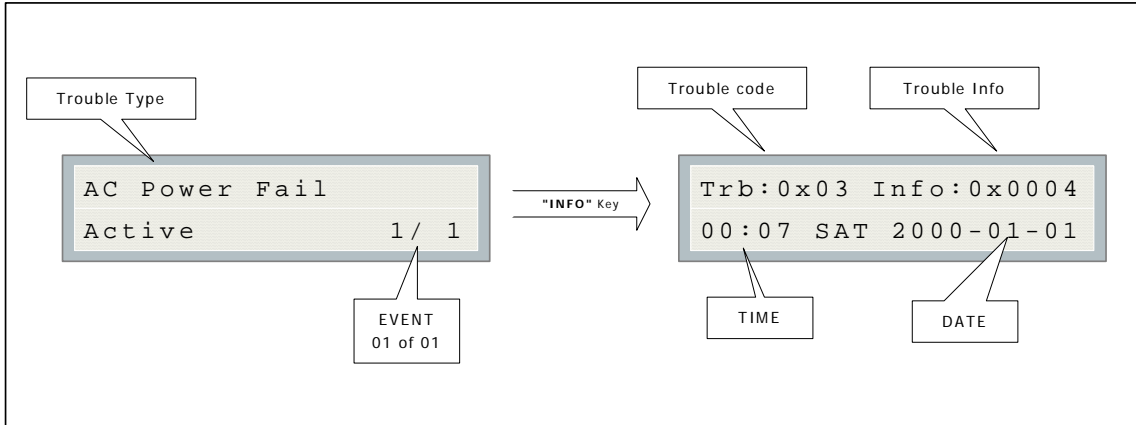

Battery Trouble

The “Battery Trouble” message indicates that the battery voltage has dropped below the minimum value. The trouble is restored when the voltage returns to the normal value.

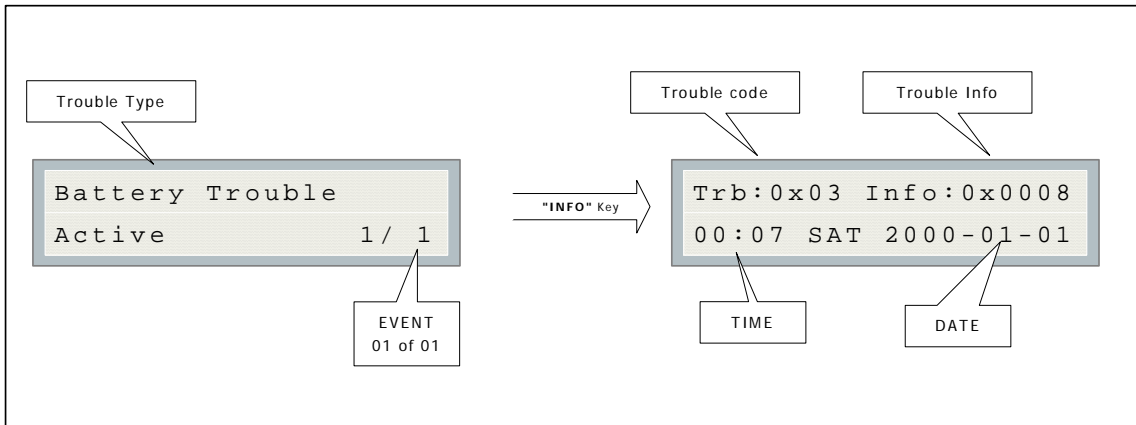

Note: The trouble code is a reference code for trained service personnel only.

Ground Fault

The “Ground Fault” message indicates that

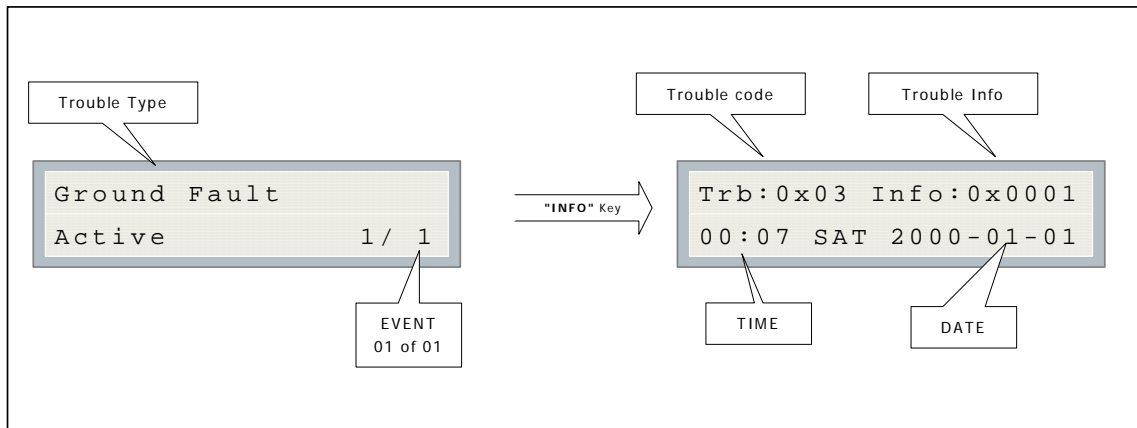

RAU num mismatch

The “RAU num mismatch” message can display for one of two reasons: either the main panel and annunciator failed to communicate with each other or an unconfigured remote annunciator is communicating with the main panel. In both the cases, the following trouble message is displayed:

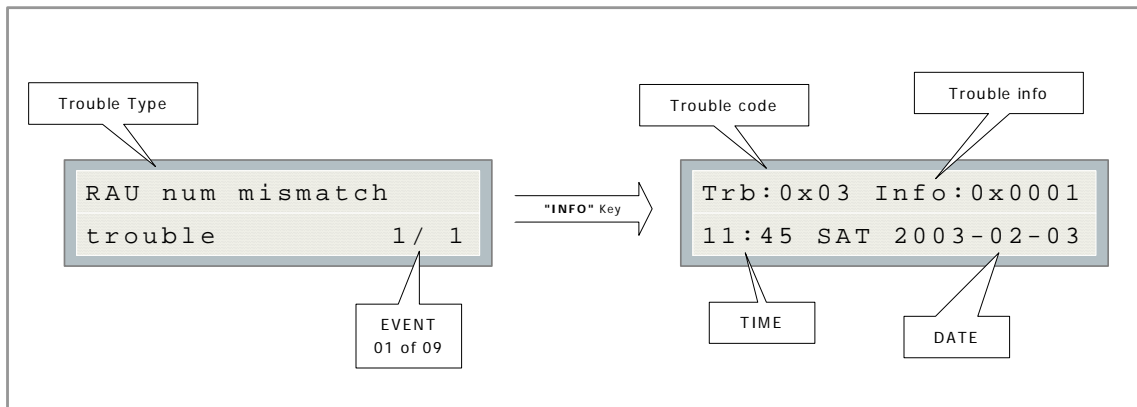

Note: The trouble code is a reference code for trained service personnel only.

4Wire Pwr. Supply

The “4Wire Pwr. Supply” message indicates that the panel has detected a short on a four-wire smoke supply the power is cut off and a trouble message is generated. Press the  key to restore the power the system. If the short is removed, the panel will return to normal; otherwise the trouble message will stay.

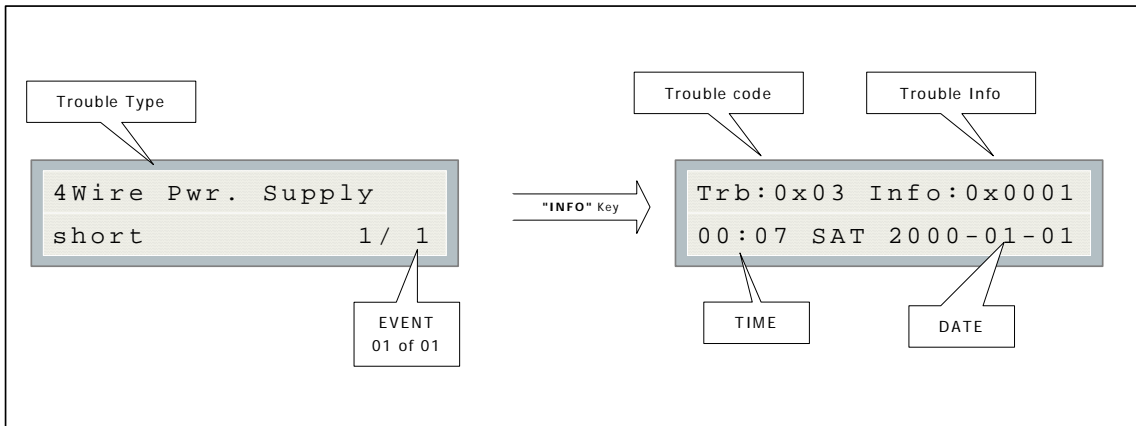

Supervised Aux-supply

The “Aux. Power Supply” message indicates that the panel has detected a short on the auxiliary power supply (battery backup) and has cut it off. Press  to restore the power the system. If the short is removed, the panel will return to normal; otherwise the trouble message will stay.

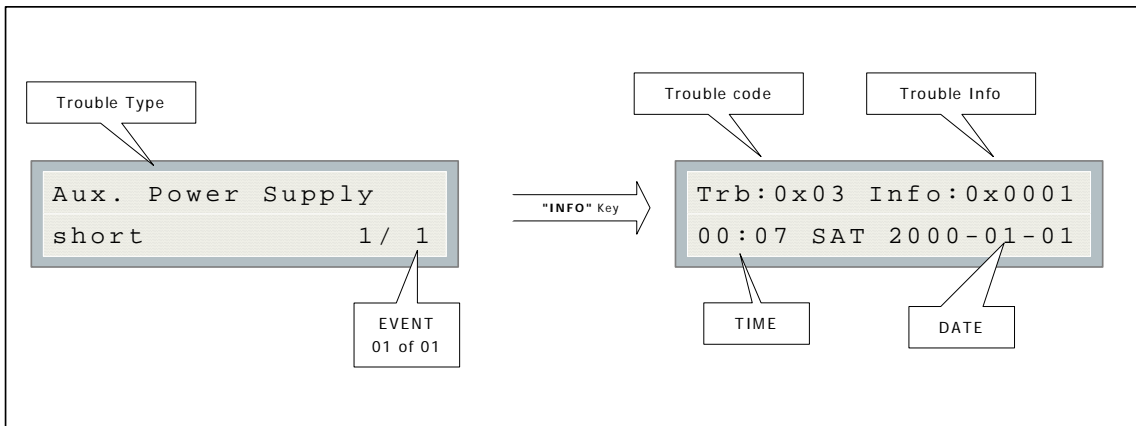

Note: The trouble code is a reference code for trained service personnel only.

City tie Polarity reversal - SPR-200/ Relay module

The “CtyTie/SRM212 missin” message below indicates that the city tie, polarity reversal module or the relay module is not plugged in.

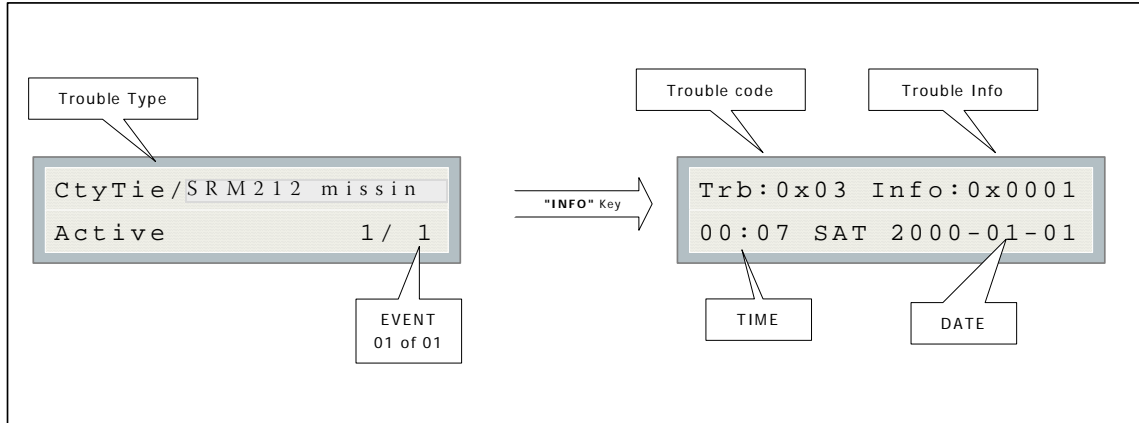

The “City Tie trouble” message below indicates that the panel detects an open on the city tie output.

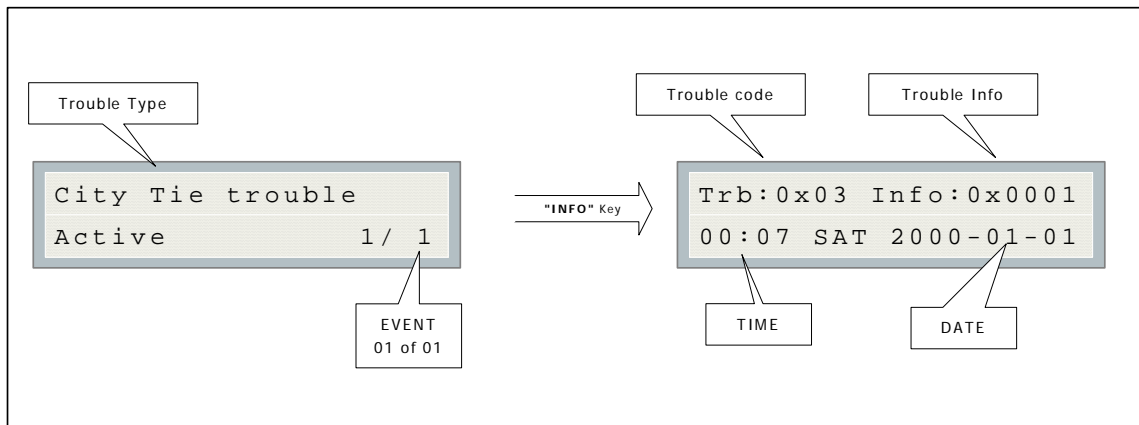

Note: The trouble code is a reference code for trained service personnel only.

Glossary

Alarm Condition

Occurs when devices such as detectors, pull stations, or sprinklers are activated. In a single stage system, this condition will activate all signalling devices throughout the building. In a two stage system, this condition will activate an alert signal and the General Alarm timer.

Circuits

Refers to an actual electrical interface and can be classified as initiating (detection), indicating (signal), or relay. The terms "circuit" and "zone" are often used interchangeably in the fire alarm industry.

Fast Flash Rate

120 flashes per minute is the rate at which an LED will flash to indicate a supervisory alarm.

Indicating Circuit

A circuit in a fire alarm system that is connected to audible or visual signalling devices.

Initiating Circuit

A circuit in a fire alarm system that is connected to detectors, pull stations, or sprinter flow switches.

Latching Circuit

A circuit that, when activated, will cause a condition on the panel that cannot be cleared until the panel is reset.

LED

The light-emitting diodes (LEDs) of the SFC-200 are colored either amber, red, or green. When lit, LEDs provide information regarding the status of the panel.

Monitor Condition

Occurs when dampers open or close, when supply and return fans are running, etc.

Non-latching Circuit

A circuit that, when activated, will cause a condition on the panel that will be cleared once the circuit is deactivated. This term is used to describe supervisory and trouble circuits.

Non-Silenceable Circuit

A signal circuit that cannot be silenced by pressing the Signal Silence button.

Relay Circuit

A circuit in a fire alarm system that connects relay devices (e.g. fan damper relays, etc).

Remote Annunciator

A device that visually indicates, either by LCD or LEDs, the floor or zone where the alarm originated.

Silenceable Circuit

A signal circuit that can be silenced by pressing the Signal Silence button.

Supervisory Condition

Occurs when the system detects open circuits, short critics, and grounds. A supervisory condition is one that would interfere with the operation of

the fire alarm system.

Trouble Condition

Occurs when an abnormal condition such as a problem in the wiring, battery or power circuits exists in the fire alarm system.

Trouble Flash Rate

20 flashes per minute is the rate at which an LED will flash to indicate a trouble condition.

Walk Test

A test performed by a technician to ensure that each detection device is connected to the panel and working properly.

Zones

A fire alarm protected area that consists of at least one circuit. The terms “circuit” and “zone” are often used interchangeably in the fire alarm industry.

